



YORK COLLEGE
OF PENNSYLVANIA



Mechanical Engineering

Student Policy Manual

Revised July 2022

Welcome to the Mechanical Engineering program!

This manual is intended to make students aware of policies and practices specific to the mechanical engineering program. This manual should be used in conjunction with the College Catalog and College Student Handbook which also delineate important student policies and procedures.

This bulletin was prepared on the basis of the best information available at the time of publication. The College reserves the right to change any provisions, regulations, or requirements set forth within, without notice.

York College of Pennsylvania
Last Revised 7/2022

Contents

1.0 Progression Policy	3
1.1 Freshman Year Requirements	3
1.2 Ongoing Requirements	3
1.3 Policy for Non-Majors	4
1.4 Notification Process	4
1.5 Appeals Process	4
2.0 Change of Major Policy	5
3.0 Transfer Policy	5
4.0 Co-op Eligibility	5
5.0 Professionalism Policy	6
6.0 Project Workspace Policy	6
7.0 Locker Policy	7
8.0 Machine Shop Policy	8
9.0 Suggested Course Sequence and Prerequisite Chart.....	9

1.0 Progression Policy

This policy governs the requirements that all mechanical engineering majors must meet in order to remain a student in the program.

1.1 Freshman year requirements

To be eligible to register for any 200-level or above engineering course (with course prefixes ME, EGR or ECE), all mechanical engineering majors must:

- Have attempted all of the courses listed in Table 1.
- Have a GPA of 2.5 in the technical courses listed in Table 1.
- Have no more than two grades of W, 0, or 1 in the courses listed in Table 1. Students who earn more than two grades of W, 0, or 1 in these courses will be dismissed from the program.

Additionally, students who do not earn a grade of 2 or better (i.e. 0, 1 or W) in any of the courses listed in Table 1 may repeat the course only one time. Failure to earn a grade of 2 or better on the second attempt will result in dismissal from the program.

Table 1: Required freshman level courses

Technical Courses	General Education Courses
MAT 171 – Calculus I	FYS 100 – First Year Seminar
MAT 172 – Calculus II	FCO 105 – Rhetorical Communication
EGR 100 – EPADS I	
ME 100 – Intro to Mechanical Engineering	
CHM 134/135 – General Chemistry	
PHY 160 – Engineering Physics – Mechanics	
EGR 150 – Computational Methods in Engineering	

1.2 Ongoing Requirements (sophomore level and above):

All mechanical engineering majors must:

- Maintain an overall GPA of 2.5 or better.
- Have no more than two grades of 0, or 1 in the courses listed in Table 2.
- Have no more than two withdrawals in the courses listed in Table 2.
- Pass (grade of 2 or better) each course in Table 2 within two attempts, including withdrawals.
- Pass each co-op assignment (EGR 491, 492 or 493) on the first attempt.

Failure to meet one or more of the above requirements will result in dismissal from the major.

Table 2: Upper division mechanical engineering major courses

ME course designations	EGR course designations	MAT & PHY course designations
ME 252 – Dynamics & Vibrations	EGR 240 – Math Methods	MAT 272 – Differential Equations
ME 260 – Materials Science	EGR 250 – Statics	PHY 260 – Eng. Physics – E&M
ME 261 – Materials Science Lab	EGR 264 – Strength of Materials	
ME 270 – Mechatronics	EGR 265 – Materials & Solids Lab	
ME 320 – Thermodynamics	EGR 290 – Eng. Career Seminar	
ME 351 – Instrumentation Lab	EGR 342 – System Modeling	
ME 361 – Thermal Sciences Lab	EGR 360 – Fluid Mechanics	
ME 380 – Machine Design	EGR 392 – Automatic Controls	
ME 400 – Capstone Design I		
ME 402 – Capstone Design II		
ME 410 – Heat Transfer		
ME 411 – Thermal Systems Design		
ME 450 – Finite Element Analysis		
Engineering Elective A		
Engineering Elective B		

1.3 Policy for Non-Majors

No student, regardless of their major, may take an ME designated course more than twice, including withdrawals. Students who are unable to obtain a passing grade (2.0 or higher) after two attempts will not be allowed to repeat the course.

1.4 Notification Process

Students who are dismissed from the major or deemed ineligible to register for a class in accordance with the above policies will be notified via email. Worksheets are available for students to self-assess compliance with the above policies. Students are strongly encouraged to track their compliance and consult with their faculty advisor with concerns and/or questions.

1.5 Appeals Process

Students who are dismissed from the major or deemed ineligible to register for a class in accordance with the above policies may submit a written appeal. Written appeals must be submitted to the department chair by the date listed in the email notification. The appeal should contain a clear and concise justification for an exception to the applicable policy. Students will be notified of the outcome of their appeal after the appeal has been discussed by the ME faculty, normally within fifteen (15) business days after the appeal has been received.

2.0 Change of Major Policy (for current YCP students)

Current York College students will only be allowed to switch into the mechanical engineering major if space is available. Any student who would like to change majors to mechanical engineering must first demonstrate they meet all of the requirements listed in section 1.1. Students who meet those requirements must submit a mechanical engineering change of major application to Dr. Stephen Kuchnicki (skuchnicki@ycp.edu). These applications are available in room KEC 100 or from any mechanical engineering faculty member. Applications are due in room KEC 102 by May 1st. Students will be notified if they can be admitted into the program by June 15th. Those students who switch into the mechanical engineering major must meet all of the requirements in section 1.2 to continue in the major. Students interested in changing their major to mechanical engineering are strongly encouraged to meet with a mechanical engineering faculty member for assistance in scheduling the courses listed in Table 1.

3.0 Transfer Student Policy (for non-YCP students)

Students will only be allowed to transfer from another institution into York College's mechanical engineering major if space is available. All transfer students must submit an official application through York College's Admissions Office with mechanical engineering listed as their intended major. Transfer students who meet the equivalent of all of the requirements listed in section 1.1 will be considered for direct admission into the mechanical engineering major. Students who have not completed the equivalent of the requirements listed in section 1.1 may still apply to York College. If accepted, they will enter as undeclared majors and then may apply to change majors as described in section 2.0.

4.0 Co-op Eligibility

In order to take EGR 290 (and be eligible for the first cooperative work experience) students must meet the following requirements:

- Have a cumulative GPA of at least 2.5
- Completed (with a grade of 2 or better) EGR 250 (Statics) and MAT 272 (Differential Equations)
- Completed (with a grade of 2 or better) or be currently enrolled in EGR 264 (Strength of Materials) and ME 320 (Thermodynamics)

5.0 Professionalism Policy

One of the stated goals of the Mechanical Engineering program at York College is to train students on the standards and expected behavior of a professional engineer in the field. With this in mind, the Mechanical Engineering faculty expect the following from every student, consistent with the conduct of a practicing engineer:

- Respect for and courteous interaction with peers, faculty and facilities;
- Integrity, which includes at its core honesty, responsibility and accountability for one's own actions;
- Sensitivity and appreciation for diverse cultures, backgrounds, and life experiences which promote engineering excellence;
- Constructive evaluation, which means that criticism is offered and accepted in a productive manner;
- Self-reflection and identification of one's own strengths and weaknesses;
- Responsibility for one's own education and learning;
- An attitude that fosters professional behavior in colleagues and peers;
- Punctuality at meetings and class sessions;
- Attentive behavior during class sessions, avoiding personal or social use of cell phones, laptops, or other electronic devices;
- Acknowledgement of the Kinsley Engineering Center as a professional workplace, and treatment of this facility as a business or office space, not as an informal space.

The faculty reserve the right to enforce this code through the York College Code of Student Conduct, including but not limited to removal of offending students from meetings, classes or from the program entirely.

6.0 Project Workspace Policy

The following rules for the Project Workspace (room KEC 138) were developed by the faculty to manage use of the space, protect the health and safety of all workspace users, and to promote appropriate laboratory practices within the Project Workspace. Students are expected to treat the Project Workspace as a professional environment and above all are expected to use good judgment when working in the space. Professionalism includes wearing clothing appropriate for the work you are doing, using respectful and courteous language at all times (including both oral and written communication), keeping your workspace tidy, and respecting the work environment of the people around you. If problems arise, please notify a faculty member and we will help to resolve any issues.

- **Proper safety equipment must be used at all times!**
- Do not touch anything that is not yours.
- Clean up your workspace when you are finished each day.
- All tools signed out from the shop must be returned to the shop each day.

- Keep your project within its space. If you think your project needs more space, ask.
- Never block the walkways.
- Use of flammables or other chemicals must be approved.
- No painting in the project workspace.
- No grinding, sanding, welding or other dust producing activities are permitted in the project workspace. Use the designated areas in the shop.
- Food, drink and chewing tobacco are prohibited in the Project Workspace.
- During after hours, access is restricted to those with approved card-swipe access. Do not prop doors open or let in students without card access.
- The last person to leave should verify all doors and windows are secured.
- If in doubt, *ask*.

7.0 Locker Policy

- Lockers will be issued to sophomores, juniors, and seniors only*.
- One locker per student.
- Students can request a particular locker and it will be assigned, if available.
- Graduating seniors must check out of their locker before the last day of final exams for the semester in which they graduate.
- Students changing majors or leaving the college must clean out their lockers and notify Dixie Loser by the end of the semester.
- Should you choose to stop using a locker, you must notify Dixie Loser at such point.
- Faculty/staff may open and inspect lockers at any time should a problem be suspected.
- Remove perishable items each day.
- NO flammable items may be stored in the lockers.
- NO stickers, decals, etc. may be attached to the inside or outside of the locker.
- Students who abandon lockers, fail to clean out their lockers, or damage the lockers will be subject to fines. Such fines may restrict registration for courses or graduation until the fines are paid.

* Lockers may be assigned to freshman EPADS teams (one locker per project team) at the discretion of the faculty members teaching the courses.

8.0 Machine Shop Policy

General Shop Rules

- Students are not allowed in the machine shop without supervision
- Students are required to obey all posted shop signs and to follow all instructions specified by the machine shop managers
- Students may not use the machine shop without the permission/approval of the shop managers
- Failure to follow any of the machine shop policies may result in loss of shop privileges

Shop Dress Code and Safety

- No shorts in the weld room at any time
- No shorts in the shop between October 1 and June 1
- No open-toed or open-heeled shoes
- No loose clothing
- Safety glasses must be worn at all times

Tool Room

- Students are not permitted in the tool room unless escorted by the shop supervisor or faculty member
- Any tools that leave the machine shop must be signed out with the shop supervisor or a faculty member
- Report any damaged or worn tools to the shop supervisor

Clean Up

- Students must clean up their work areas when done
- Students must clean up all chips/debris from the machines and surrounding areas including the floor
- All tools and tooling must be returned to the designated area

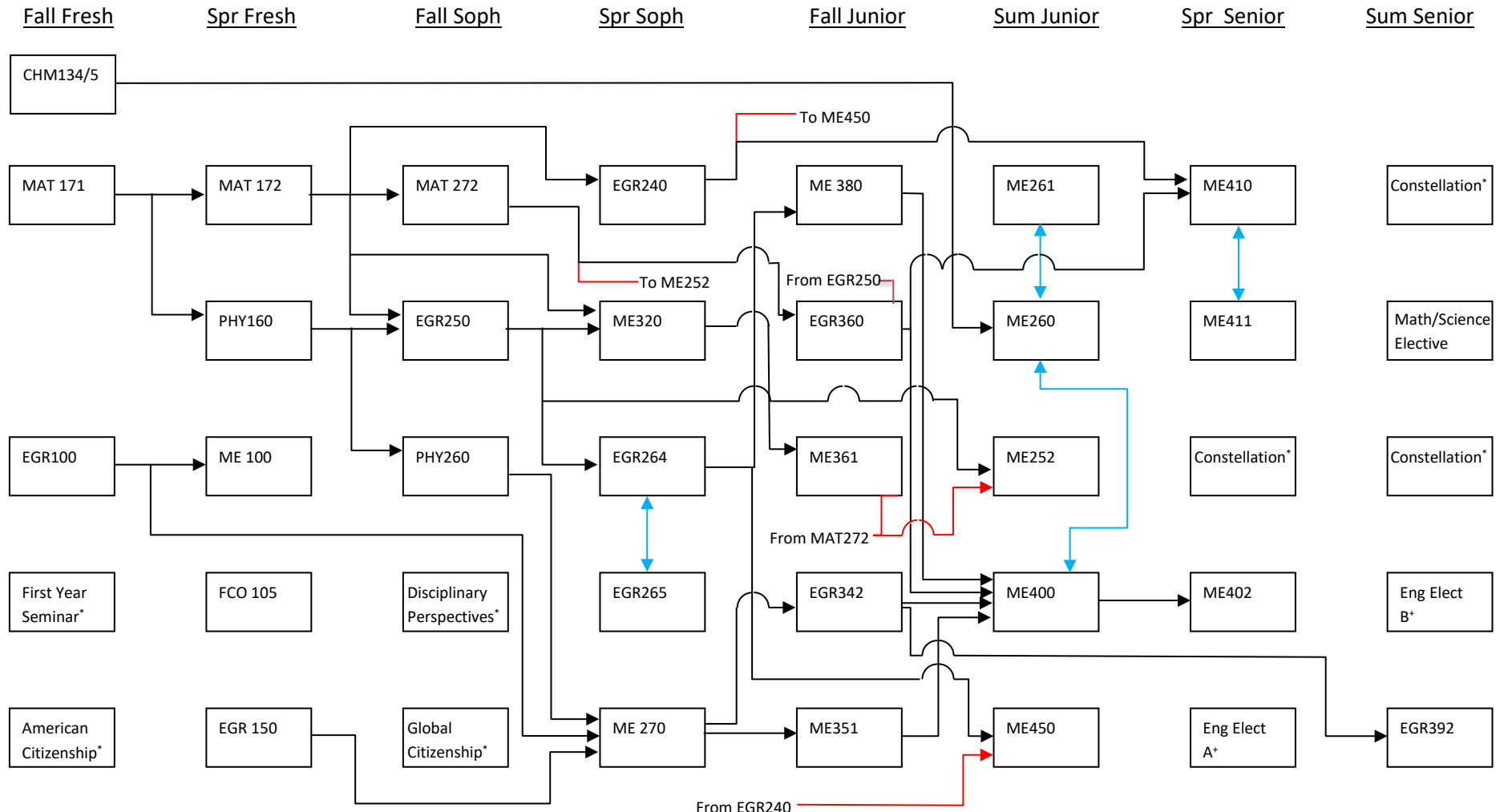

Notes:
 * Please refer to the college catalog for a list of courses that satisfy each general education requirement
 + Prerequisites for the engineering electives depend on the elective selected
 # The prerequisites for the EGR 290 course are:

- Cumulative GPA of 2.5 or greater
- Completed EGR250 (Statics) and ME 272 (Diff. Eqs.) with grades of 2 or better
- Completed (with a grade of 2 or better) or currently enrolled in EGR 264 (Strength of Materials) and ME 320 (Thermodynamics)

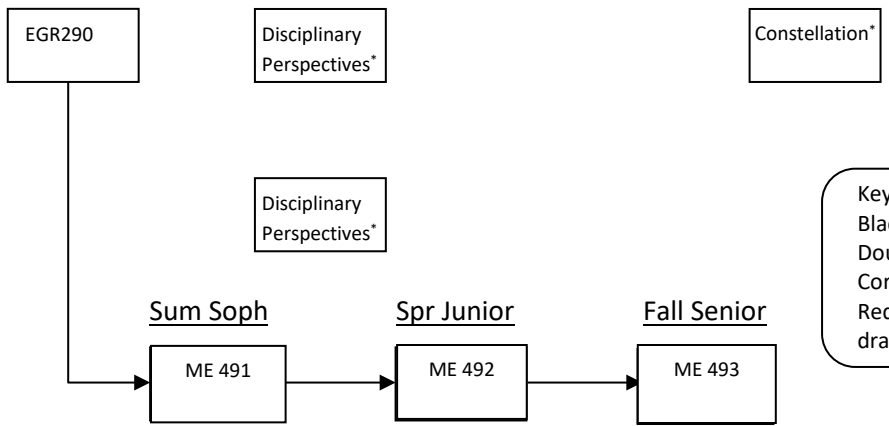

Key:
 Black Arrows – Prerequisites
 Double-ended Blue Arrows – Corequisites
 Red Lines – Broken connections drawn for clarity

